



3.03m L x 2.28m W x 1.83m H (2025 in centre)
Gable Roof GARDEN SHED
Parts list

The following parts are included in your shed:

- a. 4 x 1830 x 780mm sheets (Back wall)
- b. 8 x 1200 x 780mm sheets (Roof)
- c. 2 x narrow 1830 x 715mm sheets (beside doors)
- d. 2 x 1770 x 780mm sheets (Doors)
- e. 6 x angle cut sheets x 780mm (Gable end walls)
- f. 8 x "U" channels 3000mm long, 4 with cutouts (Front & Back) and 4 no cutouts (Roof)
- g. 2 x "U" channels 2290mm long (Top of end walls)
- h. 2 x "U" channels 2255mm long (Bottom of end walls)
- i. 4 x "U" channels 1770mm (Door sides)
- j. 2 x "U" channels 1586mm (Door spacers)
- k. 4 x "U" channels 780mm (door tops & bottoms)
- l. 4 x 1200mm "L" flashings (roof to side flashings)
- m. 2 x Gable end wall plates
- n. 3 x "Z" shaped door jambs (2 @ 1830mm & 1 @ 1770mm)
- o. 1 x 3 metre Ridge Beam
- p. 2 x GALVO Door strap - 310mm long
- q. 1 pack screws and padbolt &
- r. 1 pack of Rivets and hinges.

PLEASE NOTE: YOU SHOULD HAVE 2 PACKAGES

1 Cardboard package with the sheeting & 1 Plastic wrapped pack of channels

Caution: Some parts have sharp edges and should be handled very carefully. We recommend the use of protective gloves and footwear when assembling. All dimensions are approximate.

You will need these tools to assemble your shed:

- Battery or electric Drill
- 3.3mm (1/8th inch) Drill bit
- Screwdriver & Riveter
- Tape measure & Ladder

Feel free to phone 0800 807 433 for an installer near you...

Do not attempt to erect shed in windy weather.

- External Dimensions: 3030mm x 2280mm
- Internal Dimensions: 2985mm x 2235mm

Drawings are diagrammatic and are not necessarily to detail.

Door Assembly

Parts needed:

- d. Door sheets
- i. Door sides
- k. Door tops & Bottoms
- p. door strap
- r. hinges

Method:

Rivets are better for door assembly

1. Attach (k) door top & bottom to (d) door sheet @ centre ribs only
2. Attach (i) door sides to (d) sheet thru (k) @ 4 corners
3. Attach (p) door strap in centre of door sheet slipping under (i) fixing to sheet ribs and door sides
4. Attach (r) approx 150mm from top and bottom of door thru (i) sides. Fixing should be centred on (i).
5. turn your door over and fix 4 corners thru all "U" channels.
6. Perform same for 2nd door.

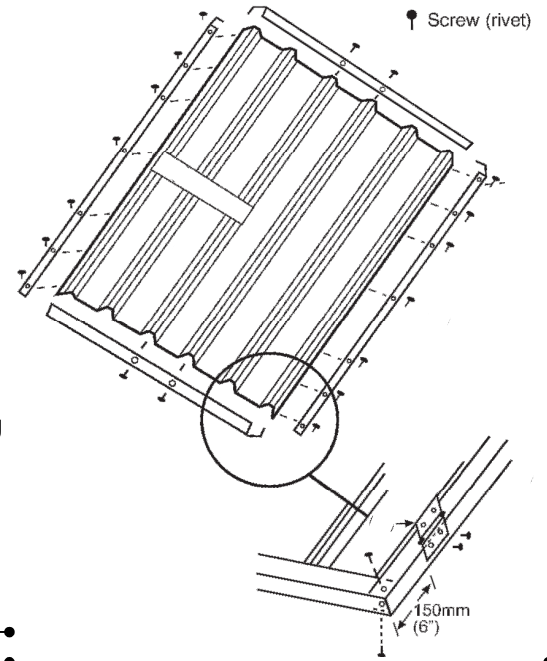

Hanging the Door

Parts needed:

- c. 2 x narrow sheets
- n. 3 x "Z" door jambs

Method:

1. Attach (n) the shortest (1770mm) "Z" door jamb to the outside of the door you prefer to open secondary
2. Attach (n) 1830mm "Z"s to narrow sheets on the rib with the narrow pan.
3. Lay the 1 of the premade doors face down on 1 of the narrow sheets approx 30mm up from bottom and down from top
4. Check door is centralised on the sheet (top & Bottom). fix hinges through side of "Z" door jamb (n).
5. Perform the same for the other door and narrow sheet. Your doors are hung.

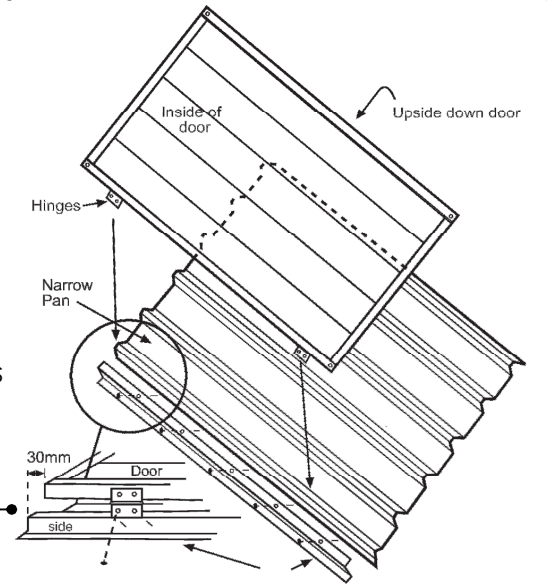

Front wall assembly

Parts needed:

- 2 x pre-hung doors (above) and 3 padbolts
- f. 2 x 3000mm "U" channels with cutouts
- j. 2 x 1586mm door spacers

Method:

1. Layout doors with the sheets attached beside them. Primary door (1st to open) on top of "Z" attached to 2ndry door.
2. Cap the sheets with (f) 3000 channels. (2 sided cutout - Top and 1 sided cutout - bottom). Channels will end short of sheeting 10 - 15mm. **Higher side of channel to inside.**
3. Use (j) Door spacers to make sure door fits gap OK (they sit on top of the jambs).
4. Drill & Fix (Rivet or screw) channels at every 2nd rib down thru the top.
5. Attach door spacer at each end thru "Z" door jambs and channels.
6. 6 fixings underneath thru channels into sheeting pan & top and bottom of door spacers & "Z"s
7. Fit 2 padbolts to underside of secondary door and 1 padbolt to door strap on the outside of the primary (1st to open) door.

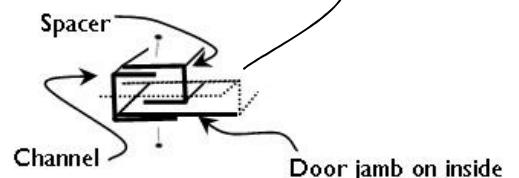
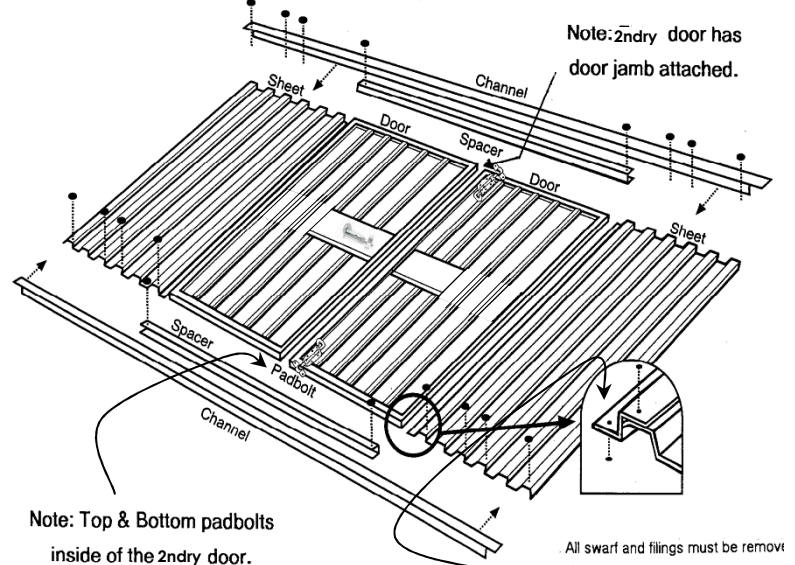

All swarf and filings must be removed

2: Back Wall

You need:

- 2 x (f) Channels with cutouts
- 4 x (a) Sheets

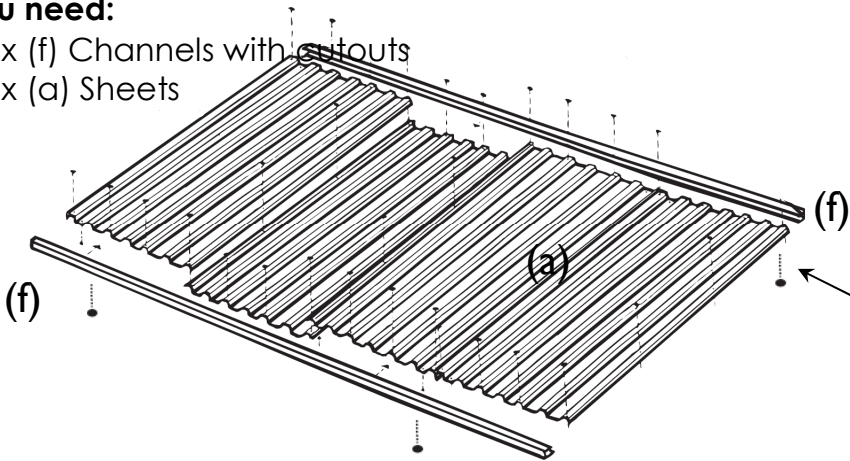

- Join 4 (a) sheets together with 2 fixings thru the overlapping ribs making sure the ends of the sheets are flush.
- Cap sheeting with (f) channels putting the cutouts top and bottom same as the front wall.
- Fix the channels thru the end ribs and every 2nd rib between.
- Make sure you put at least 1 fixing per sheet up thru the underside of the channel into the pan of the sheet.

3: Roof

You need:

- 4 x (f) Channels
- 8 x (b) 1200 Sheets
- 4 x (l) "L"s
- 1 x (o) Ridge beam

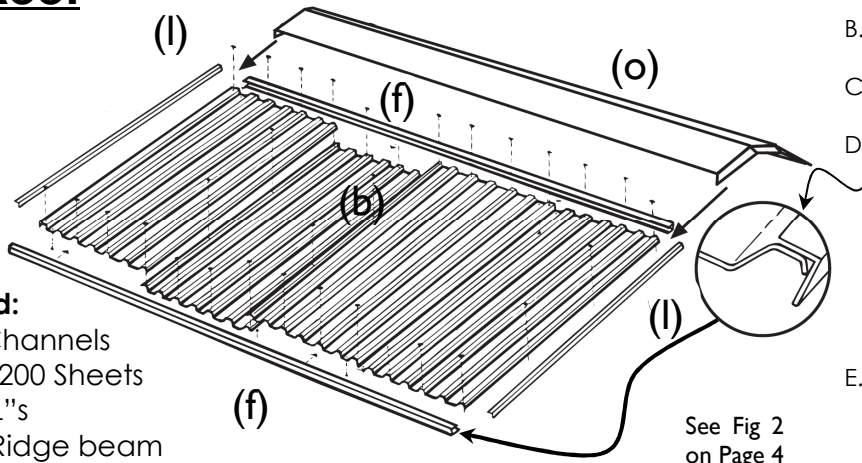

See Fig 2 on Page 4

- Join 4 (b) 1200mm sheets together same as the back.
- Cap sheeting with (f) 3000mm channels. (no cutouts)
- Fix the channels every 2nd rib but not the corners at this stage
- Place the short flange of (l) "L" on top of the rib at 1 end. Make sure ends are flush with sheeting and put 1 fixing in the centre to hold the "L". Fix the corners thru the channels and 1 more between the corner and the centre fixing. Perform the same at the other end and next roof panel
- Fit (o) Ridge beam to one roof panel and fix thru internal flange and thru the ends of the ridge beam into "L".

4: End Walls

You need:

- All the (e) Gable Sheets
- 2 x (h) 2255 Channels
- 2 x (g) 2290 Channels
- 2 x (m) Gable plates

Channels will end 10 - 15 short of sheeting

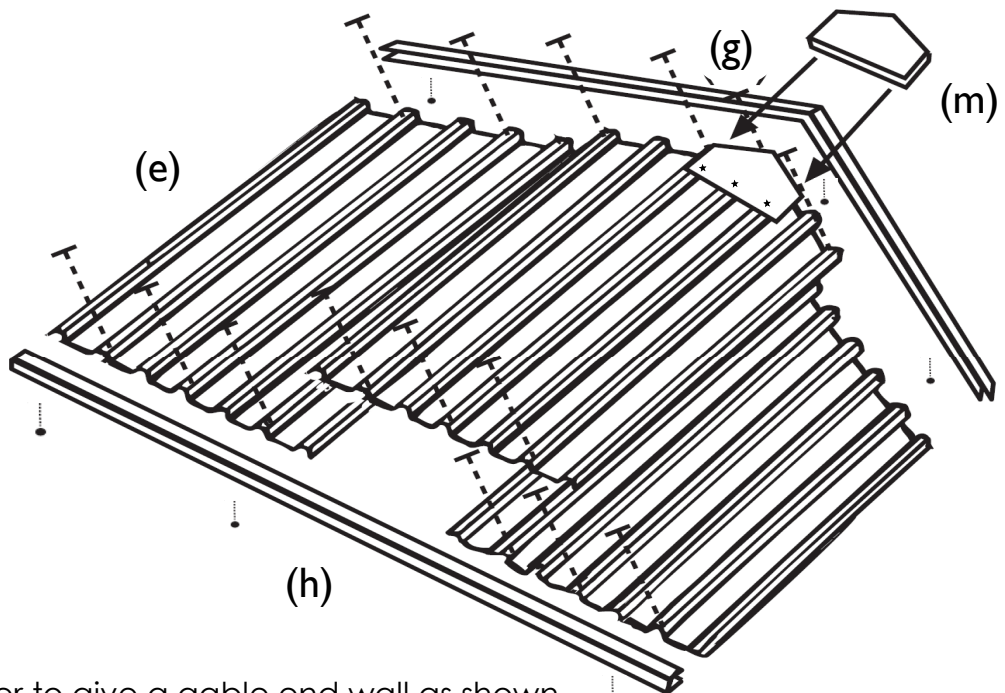

- Join 3 (e) sheets together to give a gable end wall as shown.
- Make a cut in the flanges only at (1145mm) the centre of the 2290 channels
- Cap the bottom of the sheets with a (h) 2255mm channel and bend the cut 2290 channel over the top of the sheets. Fix at corners only for now.
- Slip (m) Gable plate under channel at the top & fix to sheeting at the ★'s
- Fix the channels at every 2nd rib and thru gable plate into sheeting ribs.
- 3 fixings up underneath thru channel into pan of sheet
- Perform the same again for the other end.

Well done you have finished the panels....

Points to note as you construct your shed:

- **Do not** attempt to assemble panels in windy conditions
- **Make** sure your foundations are squared and level before erecting panels.
- **It is** easier to remove all swarf (filings) before you stand your walls up
- Complete **all** panels before erecting your shed.
- Keep a firm grip on panels when handling. If they slip they will cause damage
- Always wear non slip gloves protective footwear and eyewear.

5: Now to join your corners and put your roof on....

1st: Stand up the back wall and as your helping hand is holding it up bring the one end wall into meet it at the left corner overlapping the corners as Fig 1. Drill & Fix at approx 100mm down from the top and up from the bottom drilling and fixing from the outside. Make sure the walls are sitting flat and flush at the bottom.

2nd: Bring the other end wall into the right back corner and perform the same again checking the bottoms are flush

3rd: Bring the front wall into place and join the front corners to the end walls same as the back.

4th: Finish joining corners by fixing at approx 300mm apart. You will find it easier to drill these corners if they are supported on the inside. Use the handle end of a hammer into the inside of the corner, but beware of drilling holes in the end of your hammer.

5th: With a person at each end of the roof panel with the Ridge beam attached, waft it over top of your upright walls and lower down on top. Have your helping hand go inside and make sure the roof panel is centralised by having the ridge beam sitting right on the apex of the channel at the peak of the end wall. Fix the "L" thru the top channel to both end walls at the 1st rib in from the lowest corner making sure it is still centralised. The ridge beam will not be held down at this stage.

6th: Now waft the 2nd roof panel onto the walls, slipping it into the ridge beam. Make sure it is sitting firmly into ridge beam and then fix it to the inside flange of the ridge up underneath. (Fig 2) Now finish off fixing the "L"s to the top channels at both ends. Fix at 300mm apart and also thru end of ridge beam into "L"s. If you find the roof is binding and not wanting to sit squarely on the walls, this will be caused by unlevel site **or** walls are not square. Adjust accordingly.

7th: Using your ladder and tape measure, fix down thru the top of the roof, thru the pan into the top channel of front and back walls. (10mm more than the overhang). Fix beside every 2nd rib. (Fig 3). You will not need to worry about these fixings leaking as any water seeping thru these fixings will end up on the outside of the walls.

8th: Attach padbolt to door strap if not already done so. Check that all swarf is removed and most importantly....

9th: Fix your shed down to its foundations. If your foundations are unlevel or bowed, you will have problems with your padbolt and door levels. This can be fixed by slipping a spade under either door jamb and lifting. You will soon get a feel for which side needs propping up.

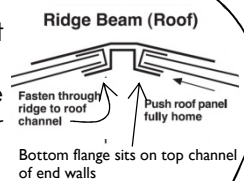
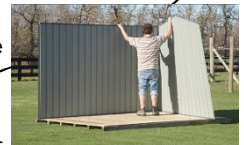

Fig 2

Well done!

Recessed floor clamps
For especially poured floors with recess around perimeter.



Flat floor clamps
For existing concrete only. Water can seep underneath.



It is **utmost** essential that every shed has a floor, but the only way to make sure your shed is there to stay on windy sites is with a recessed concrete floor **and** phone **0800 80 SHED** for more free advise.

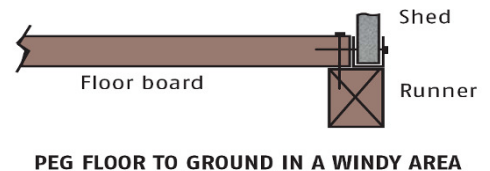

Feedback....

As we are forever trying to make sure you are our happiest customer, we are always on the look-out for ways in which we could do better. Please fax us on **06 878 5758** with your thoughts. To help you we have listed a few aspects that we would like you to comment on.

1. Finding out about our range of garden sheds and the various options we offer....
2. The store and the sales person that you purchased from....
3. The delivery and the overall dealings for the purchase of your shed....
4. The assembly of your shed and clarity of instructions....
5. Did the shed fit your needs?
6. What would you order differently next time?

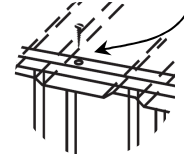

Fig 3



STORETECH
INDUSTRIES LTD

PO BOX 14175, MAYFAIR, HASTINGS, NEW ZEALAND.
TELEPHONE 06 878 5754 FAX 06 878 5758